

INTRODUCTION

TxIsoBlock and **TxIsoRail** are fully programmable isolated temperature transmitters dedicated to Pt100 and thermocouple industrial sensors.

TxIsoBlock is a head mount unit and **TxIsoRail** is a DIN rail mount unit. Both units can be easily user configured for input type and working range by means of an interface cable connected to a PC RS232 port.

Why use isolated transmitters?

Isolated transmitters protect the electrical instruments by eliminating ground loop effects and reduce substantially the undesirable interferences and instabilities in sensor measurements.

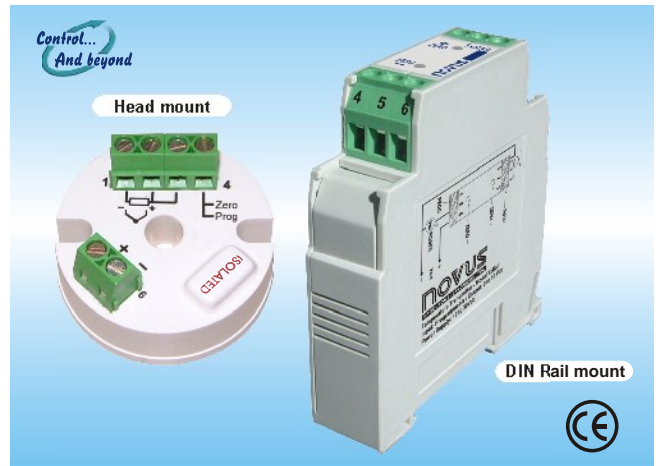

FEATURES

TxIsoBlock (for head mounting) and **TxIsoRail** (for DIN rail mounting) are two-wire signal conditioning devices that deliver 1500Vac isolation between input and output.

These devices can be fully programmed by the end user for different industrial applications.

One single model can be configured to accept several thermocouple types and Pt100 RTDs. **TxIsoRail** can also accept 0 to 50 mV and 4-20mA field signals.

The flexibility of in-the-field configuration translates into a one model fits all signal conditioning and isolator module.

CONFIGURATION

Configuration is achieved by means of an interface cable connected to a RS232 PC port along with the convenient configurator software **TxConfig**.

Through this convenient software, the end user can easily configure the input type, the desired working range and the necessary upscale or downscale protections.

Minor sensor error corrections can also be made whenever necessary.

SPECIFICATIONS

- Programmable input: thermocouples type J, K, T, E, N, R, S, B, Pt100 RTD, and (**TxIsoRail**) 0-50mV, 4-20mA.
- User programmable working range.
- 2-wire loop powered 4-20mA or 20-4mA output.
- 2 or 3-wire Pt100 input with linearized output.
- Cold junction compensation for thermocouples.
- TxRail option: 0 to 10Vdc.
- **TxConfig** Windows configurator software.
- Configuration with a PC via an RS232 interface cable.
- Manual zero (offset) adjustment can be done by means of a wire jumper simulating a keyboard for the **TxIsoBlock** or with 2 front keys in the **TxIsoRail**.
- Power supply: 12 to 35Vdc.
- Accuracy: Pt100 and 0 to 50mV ±0.15% of full scale Thermocouples ±0.25% of full scale ±1°C.
- Temperature effect: 0.003% of maximum SPAN/°C.
- Working temperature: -40 to +85°C (-40 to 185°F).
- Sensor failure protection: programmable burnout upscale or downscale.
- Dimensions: **TxIsoBlock**: 44mm (Diam.) x 25mm (H including bornes). Screw fix. Centers : 33 to 40mm.
- **TxIsoRail**: 72mm (H) x 78mm (D) x 19mm (W).
- Isolation: 1500Vac between sensor input and 4-20mA output loop.
- Selectable mains filter: 60Hz or 50Hz.

PC CONFIGURATOR

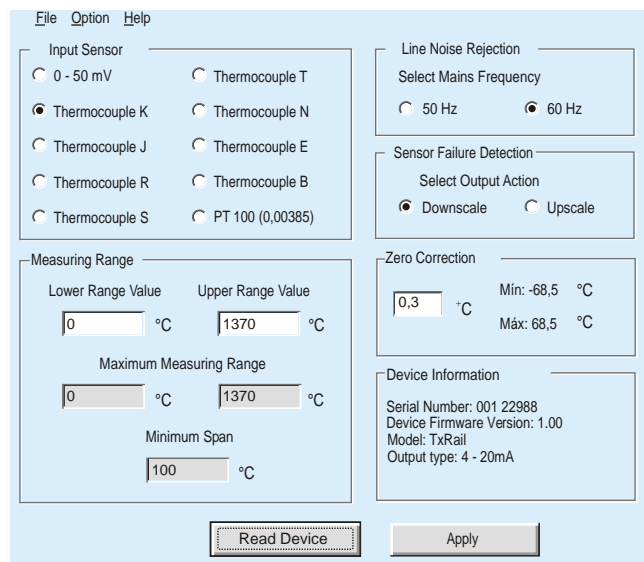

INPUT TYPES AND RANGES

Users can easily program input type and temperature range as below:

INPUT	MAX. RANGE	MIN. SPAN
• Thermocouple K	-150 to 1370°C / -238 to 2500°F	100°C
• Thermocouple J	-100 to 760°C / -148 to 1400°F	100°C
• Thermocouple R	-50 to 1760°C / -58 to 3200°F	400°C
• Thermocouple S	-50 to 1760°C / -58 to 3200°F	400°C
• Thermocouple T	-160 to 400°C / -256 to 752°F	100°C
• Thermocouple N	-270 to 1300°C / 454 to 2372°F	100°C
• Thermocouple E	-90 to 720°C / -130 to 1328°F	100°C
• Thermocouple B	500 to 1820°C / 932 to 3308°F	400°C
• Pt100	-200 to 600°C / -328 to 1112°F	40°C
• Voltage	0 to 50mV	5mV
• Voltage	0 to 10V	1V
• Current	4 to 20mA	2mA

BLOCK DIAGRAM

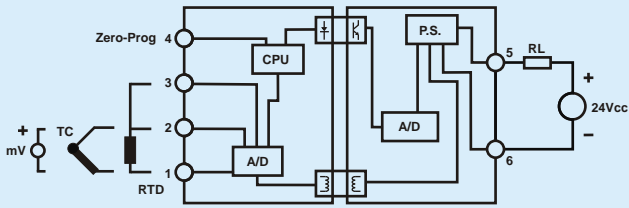

LOAD & POWER SUPPLY

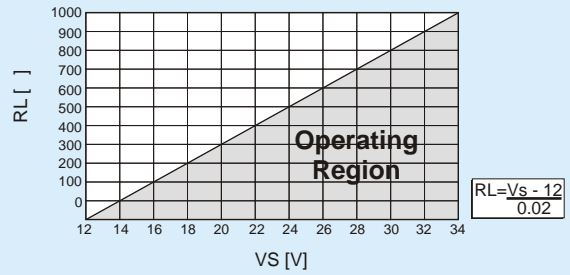

TxConfig CONNECTIONS

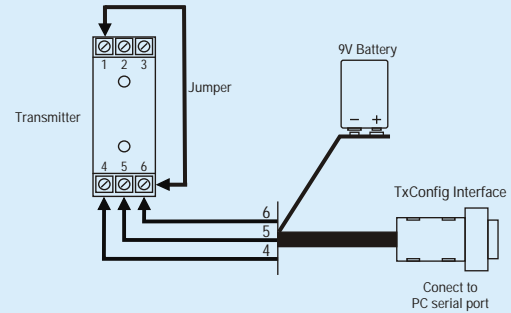
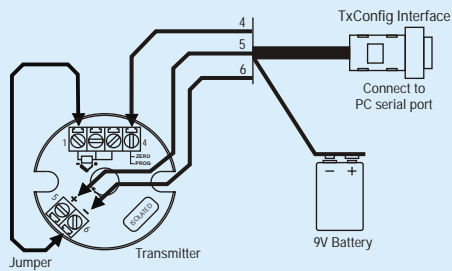

ELECTRICAL CONNECTIONS

Pt100

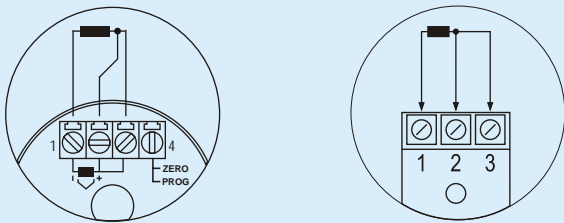

Thermocouple

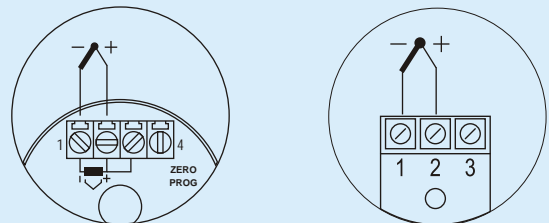

4-20mA

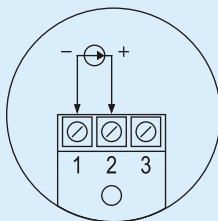

Output

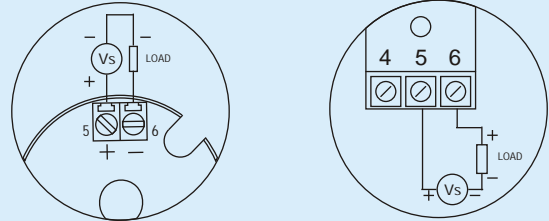

DIMENSIONS

TxIsoBlock

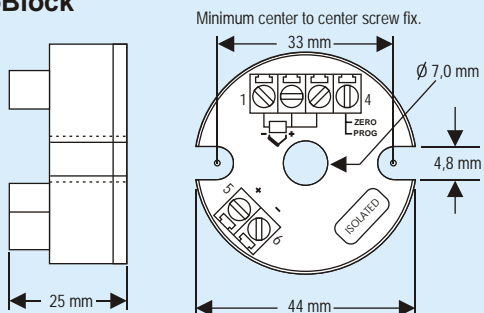

TxIsoRail

