

**Position Transducers
With Restoring Spring
10, 25, 50, 75, 100 mm**

TR, TRS Series

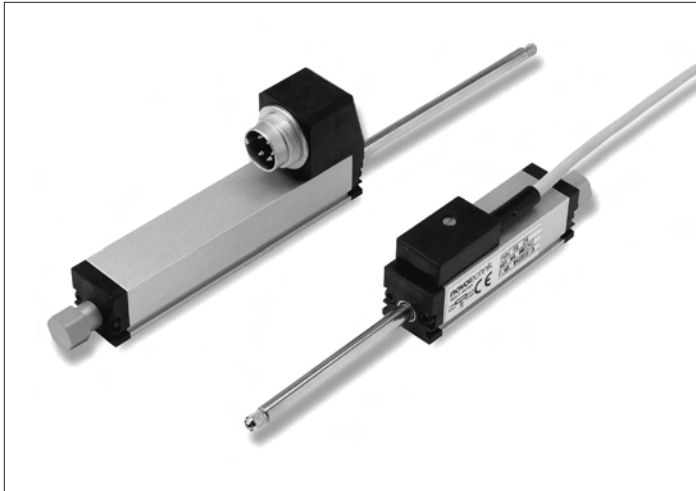

Special features

- long life – 100×10^6 movements
- outstanding linearity – up to $\pm 0.075\%$
- Repeatability to ± 0.002 mm
- choice of plug or cable connection
- DIN standard gauging end
- double bearing system on shaft
- insensitive to shock and vibration

One important feature of the TR, TRS Series is the industry proven double-bearing systems on both actuator shaft and spring. This arrangement reduces side load errors that could occur in an application such as cam-following and is one of the design factors that enables the outstanding linearity of this series.

Position sensors employing conductive-plastic resistance and collector tracks provide direct means of measuring position or profile, without the need of a solid mechanical coupling.

One important feature of the TR, TRS Series is the industry proven double-bearing systems on both actuator shaft and spring. This arrangement reduces side load errors that could occur in an application such as cam-following and is one of the design factors that enables the outstanding linearity of this series.

The back end of the actuator shaft has a special collar that allows the attachment of an air cylinder or solenoid to automatically retract the actuator when required.

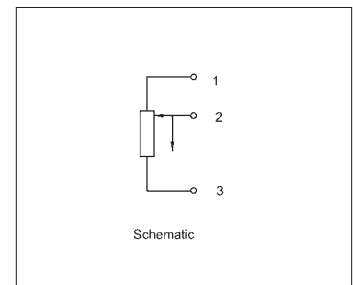
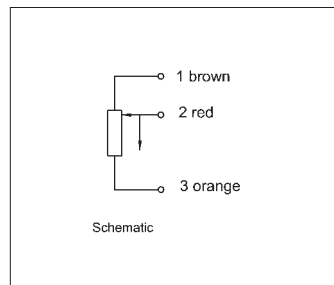
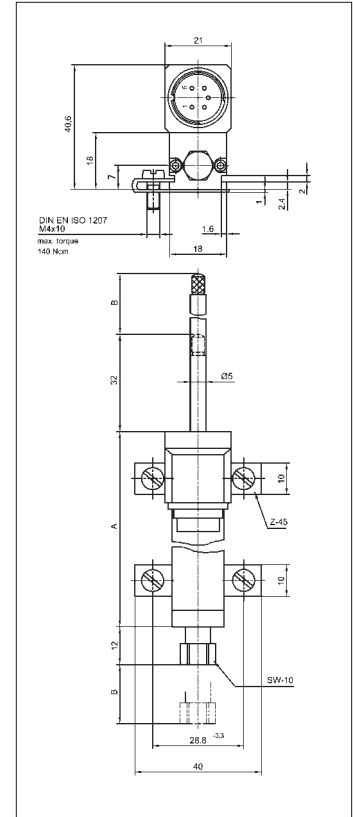
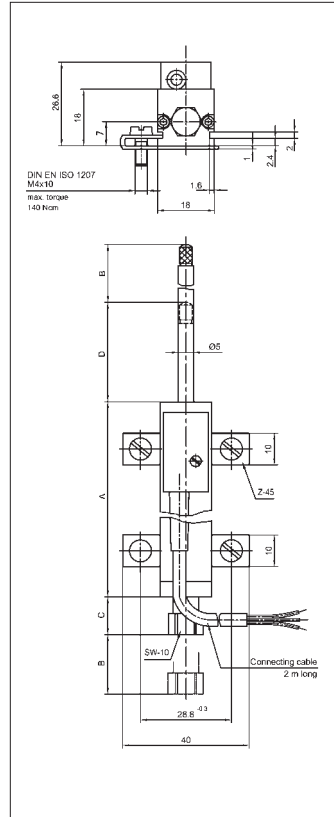

Description	
Housing	aluminum, anodized
Actuating shaft	stainless steel with anti-rotation device, inside thread M 2.5 x 6
Fixings	adjustable clamps
Gauging head	stainless steel with external M 2.5 thread and hardened ball point
Bearings	both ends in DU plastic bearings
Resistance element	conductive plastic
Wiper assembly	precious metal multi-finger wiper, elastomer-damped
Electrical connections	
type TR	three conductor stress-relieved, shielded cable, 2 m
type TRS	plug connector

Novotechnik U.S., Inc.
 155 Northboro Road
 Southborough, MA 01772

Phone: 508-485-2244
 Fax: 508-485-2430
 Email: info@novotechnik.com

Type designations	TR 10	TR 25 TRS 25	TR 50 TRS 50	TR 75 TRS 75	TR 100 TRS 100	with cable with plug
Electrical Data						
Defined electrical range	10	25	50	75	100	mm
Nominal resistance	1	1	5	5	5	kΩ
Resistance tolerance	20					±%
Independent linearity	0.25	0.2	0.15	0.1	0.075	±%
Repeatability	±0.002					mm
Recommended operating wiper current	≤ 1					μA
Max. wiper current in case of malfunction	10					m
Max. permissible applied voltage	24	42	42	42	42	V
Effective temperature coefficient of the output-to-applied voltage ratio	typical 5					ppm/°K
Insulation resistance (500 VDC, 1 bar, 2 s)	≥ 10					MΩ
Dielectric strength (50 Hz, 2 s, 1 bar, 500 VAC)	≤ 100					μA
Mechanical Data						
Overall length (dimension A)	48	63	94.4	134.4	166	+1 mm
Mechanical stroke (dimension B)	15	30	55	80	105	±1.5 mm
Dimension C (at TR)	7	12	12	12	12	mm
Dimension D (at TR)	6	32	32	32	32	mm
Weight with cable	80	120	150	180	200	g
Weight with plug		74	100	128	150	g
Weight of the actuating shaft with coupling and wiper block	18	25	36	48	57	g
Operating force (horizontal)	≤ 5					N
Operating frequency max. (In critical applications mount the transducer with the gauging head upwards.)	20	18	14	11	10	Hz
Maximum permitted torque for fixing screws	140					Ncm

Included in delivery

2 fixing clamps Z 45 incl.
 4 screws M4x10,
 1 gauging head with hardened ball point

Recommended accessories

Plug type EEM 33-70, protection class IP 67
 Plug type EEM 33-71, protection class IP 40
 Plug type EEM 33-72, protection class IP 40
 1 roller head Z 50
 Process-controlled indicators MAP... with display,
 Signal conditioner MUP.../MUK... for standardized output signals

Important

All values given for this series – including linearity, lifetime, micro-linearity, resistance to external disturbances and temperature coefficient in voltage dividing mode – are quoted for the device operating with the wiper voltage driving an operational amplifier working as a voltage follower where virtually no load is applied to the wiper ($I_e \leq 1 \mu A$).

Environmental Data		
Temp. range	-30...+100	°C
Vibration	5... 2000	Hz
	$A_{max} = 0.75$	mm
	$a_{max} = 20$	g
Shock	50	g
	11	ms
Life	> 100 x 10 ⁶	movements
Protection class	IP 40 (DIN 400 50 / IEC 529)	

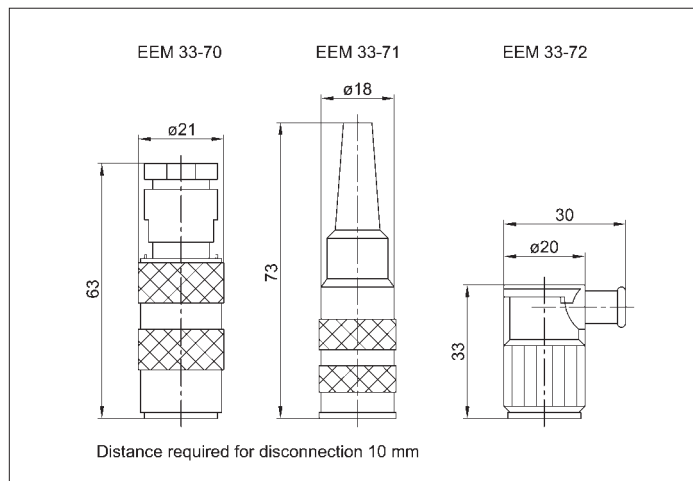

Order designations

Type	Art. no.
TR 10	002360
TR 25	002361
TRS 25	002371
TR 50	002362
TRS 50	002372
TR 75	002363
TRS 75	002373
TR 100	002364
TRS 100	002374

Subject to changes

© December 2001, 2002

Novotechnik U.S., Inc. All rights reserved.